

Results of the procedure for selecting manufacturers, considering the introduction of CBTC on our railway system

JR East is aiming to drastically change and improve our Tokyo Metropolitan Area transport system through innovations that incorporate a conceptual breakthrough and are completely free from conventional ways of thinking. Our final objective is to achieve innovations in technology (such as elimination of the need for track circuits and reduction in the number of cables), and operational innovations (such as bi-directional same-track operation). With these objectives, we have been moving forward to consider the introduction of the CBTC system on our Joban Local Line (a local line which runs between Ayase and Toride). CBTC is a communications-based train control system which is rapidly coming into use on metropolitan railways and other transport systems worldwide.

We, JR East, have received many proposals from manufacturers in Japan and from overseas. We have examined these proposals and have made thorough comparisons and detailed reviews of the contents of the proposals. We have selected 2 manufacturers with whom we will continue to work, to discuss more details of the system.

1. Names of the manufacturers we have selected

“ALSTOM” and “THALES”.

2. Details of the manufacturers we have selected

○ ALSTOM

Location of Group HQ: Levallois-Perret, Paris, France

Main areas of business: Power generation, Renewable energy, Electrical grid, Transport infrastructure

Consolidated revenue: 19.9 billion euro (Fiscal year ended March 31, 2012)

Consolidated number of employees: 93 thousand (March 31, 2012)

○ THALES

Location of Group HQ: Neuilly-sur-Seine, Paris, France

Main areas of business: Defense, Security, Aerospace, Transport

Consolidated revenue: 13.0 billion euro (Fiscal year ended December 31, 2011)

Consolidated number of employees: 67 thousand (December 31, 2011)

3. Steps in our selection of manufacturers

On June 22, 2012, JR East placed an announcement on our website homepage calling for expressions of interest from manufacturers for the introduction of CBTC on the Joban Local Line. By July 15 we had

received expressions of interest from 10 manufacturers both within Japan and overseas. JR East then asked these manufacturers to submit proposals by the end of October, providing a system outline, etc. We reviewed all of these proposals thoroughly, made comparisons, and selected the 2 manufacturers shown above, with whom we will continue to work to discuss more system details.

4. Criteria for selecting these 2 manufacturers

We sent “the criteria for selecting the manufacturer” (feasibility of accomplishing the required functions, safety and operating rate, maintenance system, CBTC introduction results etc.) to each manufacturer that had sent an expression of interest, and made a comprehensive comparison among them in assessing them.

5. Plans for the future

We will now make a more detailed review with each of the 2 manufacturers that we have selected regarding the introduction of CBTC to our Joban Local Line, and by the end of December, 2013 we will select one of these two manufacturers with whom we will officially place an order.

We plan that the actual introduction of CBTC to our Joban Local Line will occur around 2020.

6. Outline of “CBTC” (please refer to attached sheet)

“CBTC”, “Communications-Based Train Control System,” is a train control system utilizing radio technology which has been introduced widely around the world, on nearly 100 lines, mainly subways and monorail systems. (It has not yet been introduced in Japan.)

It is different from conventional train control systems where train positions are detected using track circuits. In the CBTC system, trains themselves recognize their own positions all the time, and transmit these positions to ground equipment by radio. This enables the ground equipment to control the speed of the trains by sending information to indicate to each train where it must come to a full stop. With CBTC, track circuits are no longer necessary, and the number of cables used can be reduced substantially.

In many cases, the CBTC system is not only a “train control system,” but also functions as a “traffic management system,” and is a total transport control system that can manage bi-directional same-track operation.

JR East is now considering the introduction of CBTC, a communications-based train control system, on the Joban Local Line between Ayase and Toride.

Configurations and features of the CBTC system

【Features】

1. CBTC is a comprehensive and integrated system capable of train control (controlling switch points, train headways) and traffic management.
2. It is completely different from conventional signalling systems.
 - (1) Track circuits are no longer necessary
 - (2) Information is communicated by radio
 - (3) Train headways are controlled without blocks.
3. It can manage *bi-directional same-track operation** and other operations.

* trains can run in both directions under the control of the signalling system on both the inbound line and the outbound line
4. It is already in use on nearly 100 lines worldwide.

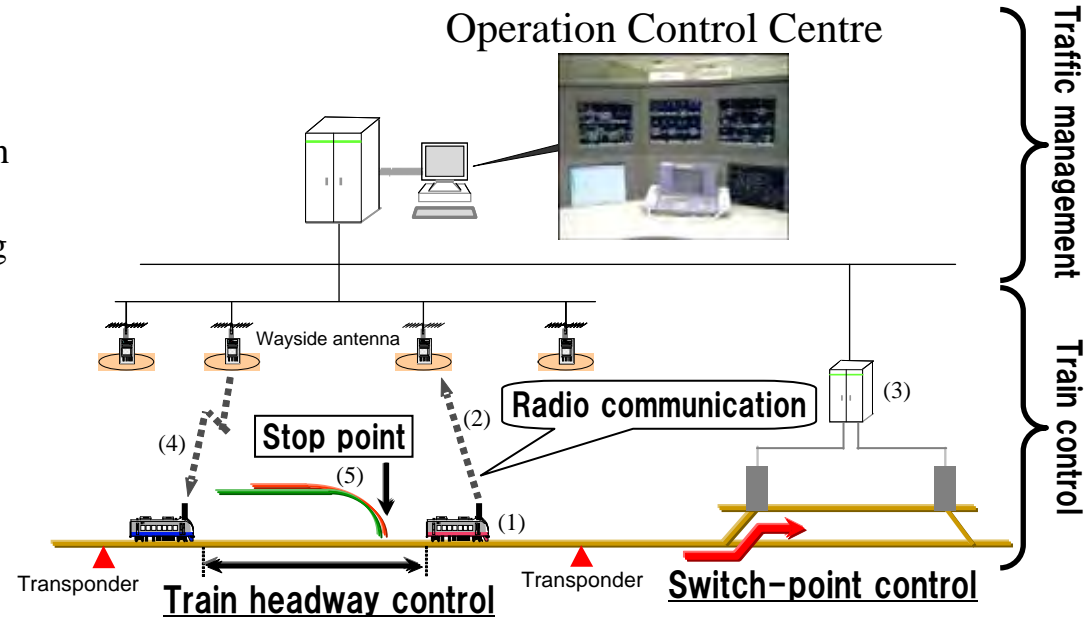

- (1) Trains always recognize their own position by transponders and their axle rotation.
- (2) Trains transmit their own position to the ground equipment by radio.
- (3) Ground equipment calculates the point where a following train must come to a full stop, based on the distance from the preceding train.
- (4) Ground equipment sends the information about this point to the following train by radio.
- (5) The following train sets its speed profile so that it can stop before reaching this point.

Examples of functions provided by CBTC on railways worldwide

No track circuits are required, and fewer cables are needed

Train positions are detected without using track circuits and transmitted by radio.

- Simplified ground facilities, and fewer troubles involving signals

Conventional method

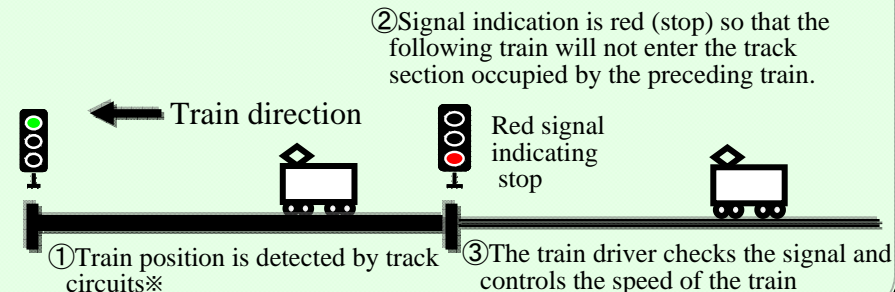

CBTC

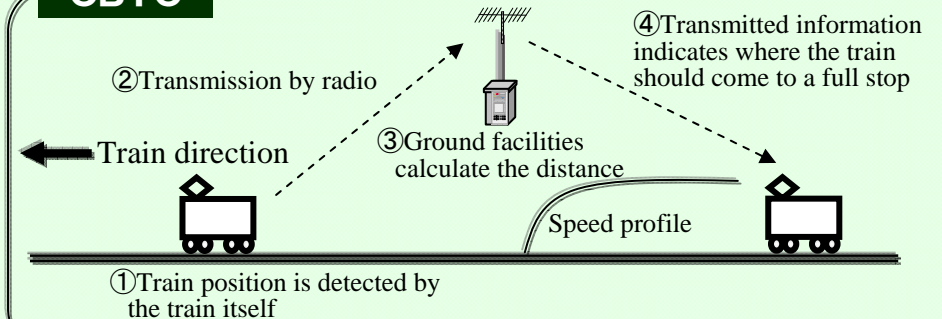

※A “track circuit” detects train positions electrically by sending electric current through the rails.
(This method is used on many conventional railways.)

Bi-directional same-track operation

Inbound and outbound trains can both operate safely on a single track under control of signals. ※

- If there is a transport disruption that blocks one of the two tracks, trains can resume operation quickly by using the other track.
- This capability permits more time for track maintenance by allowing temporary single-track operation at times when trains are less frequent and on sections that are less congested.

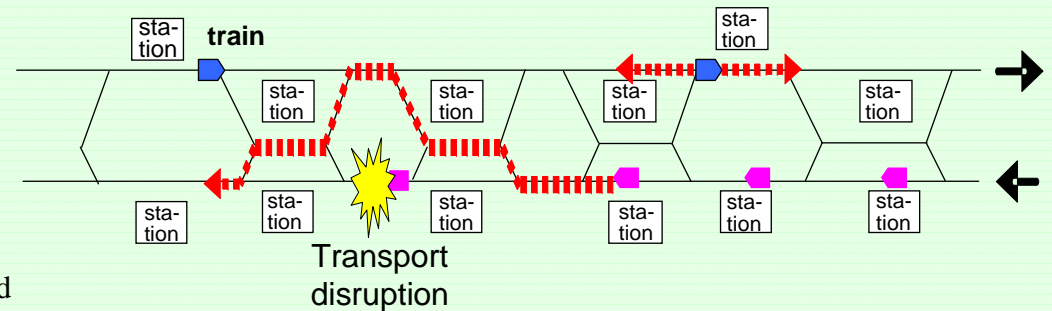

※Trains can also operate toward the opposite direction by using signals.

Railways of CBTC System in the World

The CBTC system is already in use on nearly 100 lines worldwide.

(Remark) The CBTC system has never been introduced to Japanese railway before.

Country	Railway
U.S.A.	New York City Subway (L Line), Philadelphia SEPTA (Green Line), etc.
Canada	Vancouver SkyTrain (Expo Line, Millennium Line, Canada Line), etc.
U.K.	London Underground (Jubilee Line), Docklands Light Railway (London), etc.
France	Paris Metro (Line 1, Line 3, Line 5, Line 14)
Spain	Madrid Metro (Line 7), Barcelona Metro(Line9), etc.
China	Beijing Subway (Line 2, Line 4, Line 8-10, Line 15, Fangshan Line, Daxing Line, Airport Express), Shanghai Metro (Line 6-11), Chongqing rail transit (Line 1, Line 3), Hong Kong Metro MTR (West Rail Line, Ma On Shan Line, Disneyland Line), etc.
Korea	Busan-Gimhae Light Rail Transit, etc.
Others	Dubai Metro (Red Line, Green Line), Singapore Metro (Northeast Line, Circle Line), etc.